

# OPERATIONS MANUAL

# AEROVATE 20cc Engine



**RC Aero Products**

Tel: 905.688.3947

sales@zrcgf.com

www.zrcgf.com

*Giant scale engines that surpass expectations*



# Introduction To the AEROVATE Engine

Congratulations on your purchase of the AEROVATE Engine. You have in your possession one of the strongest and most powerful engines in its class today.

The AEROVATE engine provides the Giant scale aircraft pilot the power, and performance features necessary so you can fly with confidence.

Our line up of engines are designed and engineered for RC giant scale aircraft. All our engines are modeler tested across the world. Real world results shape the engines. Performance is your reward

These engines are built to a high level of quality, and are engineered to provide years of trouble free service.

It is important for you to go through the manual to familiarize yourself with the engine and how its operations. Contact us via email or telephone if you have any questions. We are here to help you enjoy your engine.

## Table of Contents

1. Introduction to AEROVATE Engines ....	3
2. Engine specifications .....	4
3. Exploded diagram and parts list ....	5
4. Safety Instructions .....	6
5. Engine installation .....	7
6. Engine break in .....	7
9. Carburetor adjustment .....	8
10.Starting the engine .....	9
11.Engine maintenance .....	9
12.Electronic Ignition system .....	9
12.Warranty and Service .....	11
13.Procedures for warranty work .....	12
14.Getting your engine repaired .....	13
15.Contacting us .....	14

# 20cc Engine Specifications

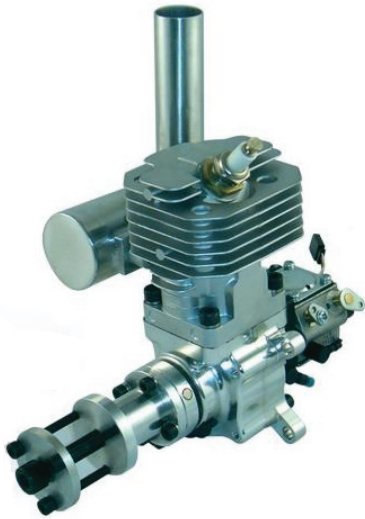

Displacement (cc)	20cc
Bore x Stroke (mm)	1.18"x1.10" (30mmx28.0mm)
Carburetor	Walbro
Ignition	DC-CDI (electronic ignition system)
Power supply	4.8-6V
Weight - with ignition and muffler	38.1 ounces (1080g)
Weight - without ignition & muffler	29.3 ounces (830g)
Maximum Output	2.2hp/1.65KW
Speed range	1500-9800rpm
Gas/Oil Mix	25-40:1 (90 octane gasoline)
Propeller	16*8 9300 rpm

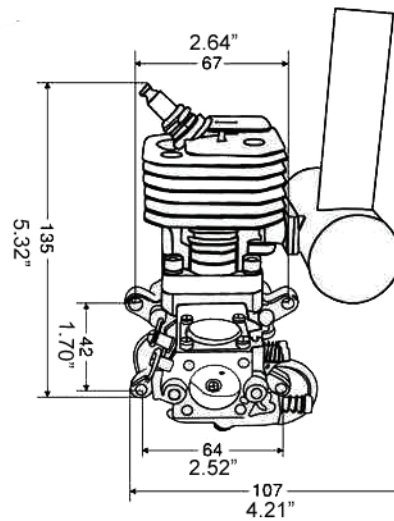
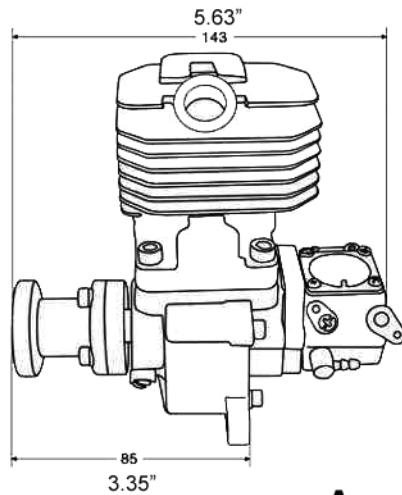

**Aerovate 20cc  
CM6 Plug**

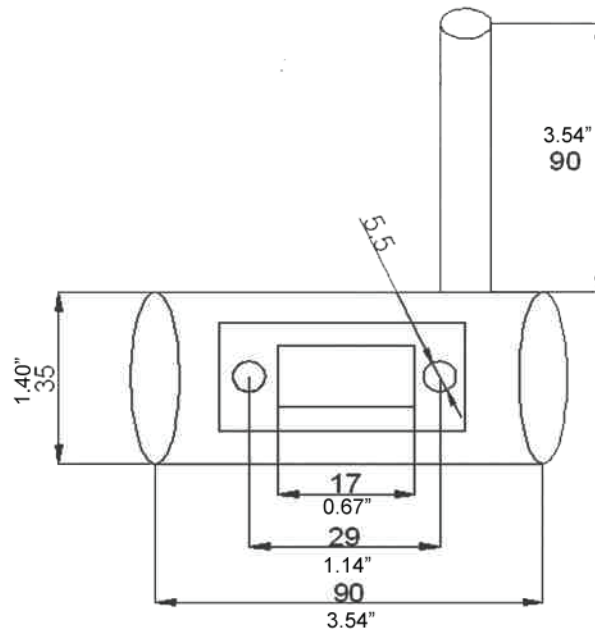

Units: Inches  
mm

**RC Aero Products**

Tel: 905.688.3947    sales@zrcgf.com    www.zrcgf.com  
*Giant scale engines that surpass expectations*

# 20cc Exploded View and Parts

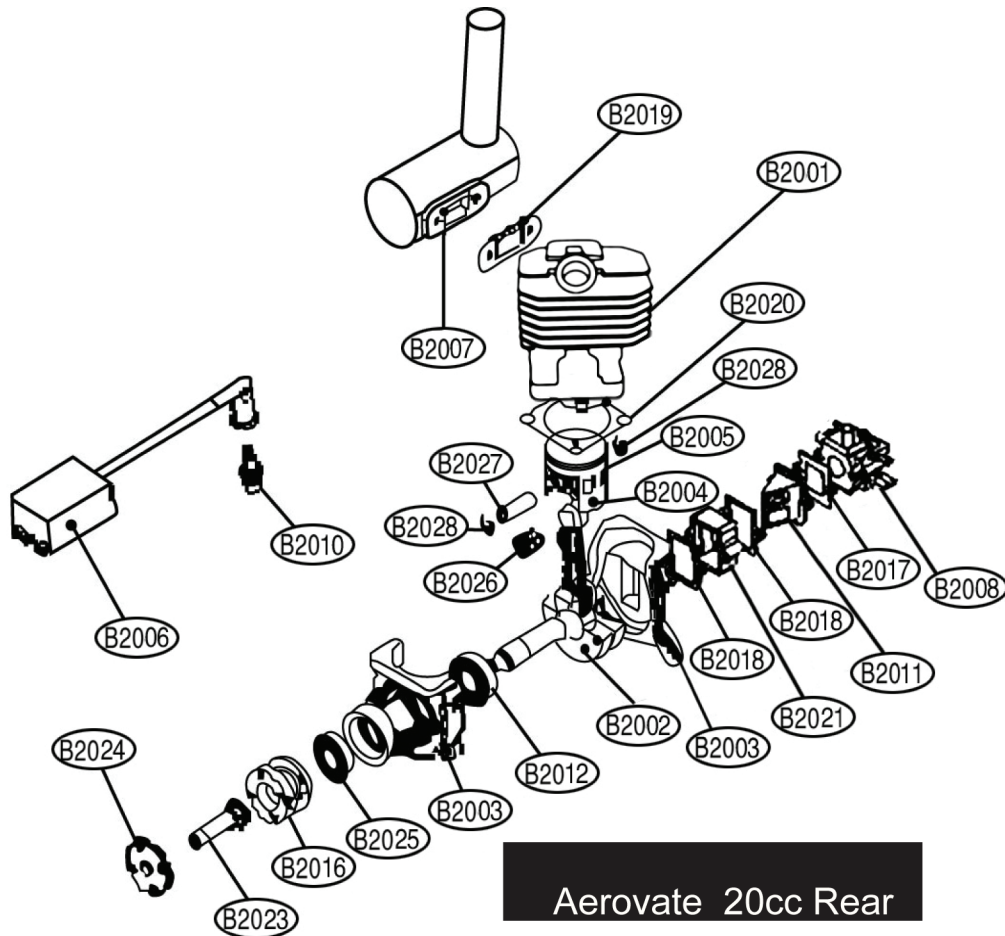

Item	Description	Accessory Number
1	CYLINDER	B2001
2	CRANKSHAFT accessory	B2002
3	CRANKCASE SET(front)	B2003
4	CRANKCASE SET(rear)	B2003
5	PISTON accessory	B2004+B2005+B2027+B2028+B2026
6	PROP HUB accessory	B2016+B2024+B2023
7	BEARINGS	B2012,B2025
8	IGNITION SET(included sensor)	B2006
9	GASKET SET	B2020+B2019+B2017+B2018
10	WRIST PIN BEARING	B2026
11	REED VALVE & INSULATOR	B2011,B2021
12	CARBURETOR	B2008
13	SPARK PLUG	B2010
14	MUFFLER	B2007
15	SCREW SET	

# Safety Instructions

## **LISTEN UP!! IMPORTANT SAFETY INFORMATION FOR THE USE OF THESE ENGINES**

**WARNING!** This motor can cause severe harm to you, and/or others, if misused or if these safety precautions and instructions are not observed. We are not responsible for any loss, injury or damage resulting from the use of its products.

- Read all the instructions before operating your engine.
- If you have any questions about any aspect of operating the engine, do not attempt to start or operate it in any way.
- You, and only you are responsible for the safe operation of your engine.
- Do not operate the engine if you do not want accept complete responsibility for any injury or damage caused or incurred during its operation.
- Verify proper ignition, receiver and transmitter battery voltages, and perform a range check before every flight.
- Never operate the engine or fly model aircraft alone.
- Turn the engine off before making any adjustments.
- Prior to operating the engine inspect motor mount bolts and firewall integrity.
- Eye protection should be used by all persons in the immediate area of the engine when the engine is running.
- Ensure the aircraft is properly secured when starting or operating the engine as it can develop tremendous thrust.
- Operate the engine in an open area. Never operate indoors.
- Always stand behind the propeller when operating the engine.
- Use a heavy duty starter stick, or a properly sized electric starter to flip and/or start the engine. Use heavy leather work gloves when flipping the prop.
- Stay away from the prop while operating the engine. Do not wear loose clothing near the engine or prop. Do not allow people to stand in front or beside the propeller when the engine is operating.
- Do not run the engine near loose material such as dirt, sand, gravel, power, ropes, cords, etc. Any loose material can be drawn into the turning prop causing injury or damage.
- Keep people and pets at least 50 feet away when operating the engine.
- Always use the proper size propeller. Never use damaged, modified or repaired propellers.
- Always use the correct type and length of propeller bolts. Never use spacers behind the propeller.
- The spinner cones must not touch the propeller.
- Some thinner props may require the use of shorter prop bolts, especially if not using a spinner back plate. Ensure your prop bolts do not bottom out in the propeller hub.
- Check that the propeller bolts are tight before every flight.
- Always install an ignition kill switch to stop the engine.
- Carburetor linkages should be adjusted so that the engine will stop when the carburetor is completely closed.
- Gasoline is extremely flammable. Do not smoke in the area of your engine and gas supply. Also sparks can come from electrical contacts on fuel pumps, battery chargers, and other support equipment. Always have a fully charged fire extinguisher nearby and ready.
- Fuel your aircraft when the engine is cool to the touch.
- After running your engine, turn your prop several revolutions. This will ensure that your ignition system is discharged.
- Never turn the engine over without ensuring the ignition system is off.
- The Ignition system develops high voltages. Never touch it during operation.
- Always fly in accordance with the safety rules, regulations and recommendations of the AMA (American Modeling Association). Read and understand all of the safety material on their website [www.modelaircraft.org](http://www.modelaircraft.org) before using this engine. In Canada, the representing body is MAAC (Model Aeronautics Association of Canada) and their website is [www.maac.ca](http://www.maac.ca)

# Engine Installation

If using mounting brackets, they should be installed with the closed end to the firewall and the open end to the engine. If using the mounting stand-offs, the cut ends should be mounted to the engine. If additional mounting height is needed, it should be placed between the mounting hardware (brackets / stand-offs) and the firewall. Make sure that all spacing is flat and of the same size and surface plane so as not to induce any twisting force into the mounting hardware or damage to the engine or mounting hardware failure may result. Spacing should never be used between the mounting hardware and the engine. In all cases, the firewall / airframe mounting surface must be absolutely flat or potentially damaging forces can be exerted to the engine or mounting hardware which can cause failure.

Check to see that the carburetor has adequate clearance (at least 1 in.) to anything for proper breathing. If it doesn't, make appropriate adjustments. Make sure that your airplanes fuel tank and lines are made for gasoline use, that the tank is adequately vented and that the feed line clunk can move freely in all directions and not get hung up anywhere. We recommend using a filter between your gas supply and airplane fuel tank. If you use a fuel filter between the airplane tank and the carburetor, make sure it is of adequate size to supply an unobstructed flow of fuel to the carburetor or the engine may not run correctly.

Make sure that the cowl openings on your plane provide enough airflow for proper cooling. Ideally, all of the cooling fins of the cylinder should be exposed directly to unobstructed flow of cooling air and there should be 3 times as much air exit area as intake area. Many planes have cowl openings that actually inhibit proper cooling of single cylinder engines. Their openings were made to give a scale appearance of the full size planes they are patterned after. Along with the openings described above, blocking the scale openings either partially or wholly can significantly help promote cooling airflow over the cylinder fins.

Many types of fuelling devices (fuel dots, filler valves, etc.) are available for your use. Our experience has shown that often the simplest is the best. Regardless of which device you decide to use, be very wary of air leaks, as they can be detrimental to the proper operation of your engine.

**NOTE:** Always use Loctite on engine mounting hardware and make sure your models firewall and engine box are adequately reinforced (pinned, soaked in thin CA, etc.).

# Engine Break In

Break in running should be done with regular 90 octane gas mixed with a high quality petroleum based 2 cycle oil at a ratio of 30:1. The engine should be run installed in the airframe with wings attached, on the ground for at least 20 minutes at 2500rpm. Ground running should be done with a slightly smaller prop and with the cowl off to promote good cooling. It is not recommended that you run the engine in a test stand, as they do not allow vibration energy to be properly dissipated. Plus, it is not needed. Your engine is ready to go.

During the break-in process (a couple of gallons of gas) the carburetor may need to be adjusted and the engine should be flown at light load and varying speed for enough time to have the oil/gas run through it.

After you have run a couple of gallons of fuel through, you can switch to a full synthetic 2 cycle oil mixed at a ratio of 50:1. Note that when you switch to synthetic 2-cycle oil, it is likely that the carburetor mixture and idle speed will need to be adjusted.

We recommend high quality synthetic 2 cycle oil. Never use outboard motor 2 cycle oil.

# Carburetor Adjustments

Every engine has been adjusted to average mixture settings, which will most likely allow the engine to start and run in most locations. However, as altitudes and barometric pressures vary by location and even by day, it is very likely that the carburetor mixture settings will need to be adjusted to obtain optimum performance.

**NOTE:** A. Never make adjustments to the carburetor while it is running. Always use a tachometer to aid in making adjustments to your carburetor.  
B. Do not remove the carburetor spring (2) as the spring helps keep the carburetor butterfly aligned properly. Merely release the ends of the spring so that it no longer holds the butterfly closed.

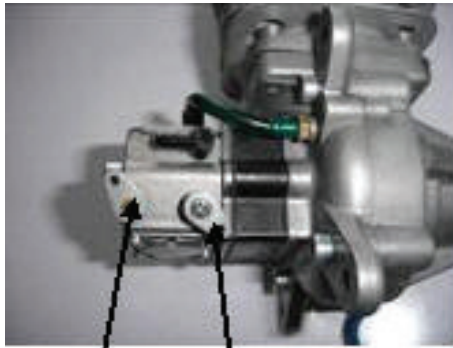

1 2



3 4 5



6

1 Choke Lever

2 Throttle Lever

3 Idle Speed Adjustment Screw

4 Low Speed Mixture Adjustment Screw

5 High Speed Mixture Adjustment Screw

6 Ignition Sensor

The average mixture settings are 1&1/2 turns out for the low speed circuit (See No. 4), and 1&3/4 turns out for the high-speed circuit (See No. 5). Carburetor mixture adjustment starts with the low speed circuit. The low speed should be set such that the transition from idle to full throttle is smooth, even if the throttle is snapped to full. This will likely result in a slightly rich idle mixture but you're better off with that than a rough transition. If the engine dies when the throttle is advanced, the mixture is likely too lean. If the engine stumbles when the throttle is advanced, the mixture is likely too rich. Since the low speed mixture has some effect on high-speed mixture, always adjust the high speed after adjusting the low.

The high-speed circuit is properly adjusted when the engine can reach maximum rpm while in the air, which is usually slightly richer than when it is on the ground. A general rule of thumb is to richen from the maximum on the ground rpm by about 200rpm. If ever the engine slows or dies while at full throttle, the high-speed mixture is likely too lean and you should adjust it as soon as possible or damage can result.

**NOTE:** Be careful not to run the mixture screws in too far as damage to the screw and / or carburetor body may result. Also, don't be tempted to run an overly rich mixture. Gas engine lubrication comes from the oil concentration in the gas, not from a rich fuel / air mixture. If you want more lubrication, you can vary the oil mix ratio. A too rich mixture will only result in poor engine performance and a fouled plug and combustion chamber.

# Starting the Engine

**COLD Step 1:** Close the choke, advance the throttle to very slightly above the idle position, turn on the ignition and briskly flip the prop through compression until the engine fires and then dies. If the gas line is dry, this may take 20 or more flips.

**Step 2:** Open the choke and briskly flip the prop through compression. The engine should start in just a few flips. If it acts like it wants to start but doesn't, you may need to advance the throttle slightly.

**WARM** Open the choke, advance the throttle to very slightly above the idle position, turn on the ignition and briskly flip the prop through compression. The engine should start in just a few flips. If it acts like it wants to start but doesn't, you may need to advance the throttle slightly.

**NOTE:** It is possible to flood the engine by over chocking. In this case, the spark plug must be removed and dried of excess fuel. Make sure to have the ignition off when removing the spark plug.

# Engine Maintenance

Fuel tubing throughout the fuel system should be changed periodically and should never allow any air to enter the system. If your gas line starts to get hard, soft or changes colour, there's a good chance it needs to be replaced. Keep in mind that the tubing inside your tank deteriorates more quickly than anywhere else in the system.

The exterior of the engine should be kept clean and inspected regularly. Tucked away inside the cowl, it would be easy to miss loose nuts and bolts without frequent inspections. Dirt inside the cowl area can easily find its way into the carburettor. It should be kept clean and free of dirt build up.

The carburetor fuel screen should be cleaned periodically also. Carefully remove the pump cover (inlet side of the carburettor), gasket and pump membrane. The screen will be visible and can be cleaned after careful removal. If ever the carburetor seems to need frequent mixture adjustment or acts like it's starving for fuel, a dirty screen is a likely candidate for a cause. The carburettor should be inspected, cleaned or reconditioned with every flying season or after being stored for a long period of time.

The spark plug should be inspected, cleaned and gapped periodically and replaced if it is fouled or worn. A new plug with every new season is a worthwhile maintenance step.

# Ignition System

## Rcexl Ignitions Ver 2.0 INSTRUCTIONS

### 1.) Specifications

I.)WARNING - Rcexl ignitions were designed for use in model aircraft and should NEVER be used in a Human Carrying Vehicle!!

#### II.)BP6MR6F 14mm and BMR6A Ignition:

Input voltage 4.8-8v  
Output voltage 12-16 kV  
Max Draw @8000 rpm - 650 ma  
Case - ABS with Nickel plate  
Weight Single: less battery - 4.4oz  
Weight Twin: less battery - 6.1oz  
Plug size - 14MM NGK (BP6MR6F)

#### III.) CM6 10mm and ME-8 1/4 32 Ignition:

Input voltage 4.8-8v  
Output voltage 12-16 kV  
Max Draw @8000 rpm - 650 ma  
Case - ABS with Nickel plate  
Weight Single: less battery - Single 4.4oz  
Weight Twin: less battery - 6.1oz  
Plug size - 10MM NGK (CM-6)

## 2.) Selecting a Power Source

I With any battery you choose, please regulate it to a maximum of 6 volts! Failure to do so will destroy your ignition!

## 3.) Installation

### I.) Spiral Wrapping:

Use the supplied Spiral Wrapping included with your Ignition to protect the wires from heat and chafing. Wrap the braided Spark Plug Lead, Hall Sensor Harnesses and Battery Harnesses.

### II.) Mounting:

Mount your Ignition on the engine box if possible. Wrap the ignition in foam to reduce the effects of engine vibration on the circuitry. You can use the mounting tabs on the ignition but we recommend using zip ties or Velcro ties to secure it. Do not install your ignition in the fuselage. Keep the ignition as far away from you receiver as possible and never use the same power source to run your ignition and receiver jointly.

### III.) Connecting the Battery:

The Rcx1 ignition utilizes the Futaba style plug ends and comes with an additional pigtail to add to your ignition switch if necessary. Be sure to follow the color coding (Red +, Black -) when attaching your to your power source and on / off switch to your ignition power leads. Wrap your battery with foam and mount it as far away from the receiver as possible, preferably on the motor box.

*Note: There are no serviceable parts in the ignition system. Opening the case will void the engine warranty.*

## 4.) Trouble Shooting your Ignition.

I.) **Battery:** Check the voltage on your battery and make sure it's healthy and fully charged. Insure that the voltage is 6v or less to the ignition.

II.) **Connections:** Check that all connections are correct from the battery, to the switch, to the ignition. Use a volt meter on the switch to ensure the ignition is getting power and the polarity is correct.

III.) **Hall Effects Sensor:** Ensure that the orientation of the hall sensor is correct with the orientation of your hub magnet.

## 5.) Safety Precautions.

Never power the ignition with the plug in the head when you're working on your engine, it could fire off!! Always wear a glove when starting your engine!! After turning off your ignition, beware that the ignition could still have a charge and fire the motor. Always range check your model!



# Warranty & Service

## WARRANTY POLICY

- All new AEROVATE Engines carry a TWO Year Warranty on Materials and Workmanship at the time of sale.
- This Warranty only applies to engines purchased through RC Aero Products, and their authorized dealers in North America.
- Engines purchased through EBAY or other sellers will not be covered for any warranty claims. Additionally, we cannot act as an agent for any claims to the manufacturer for warranty claims if the engine was not purchased from RC Aero Products or their authorized dealers.
- The Warranty is void if the engine is disassembled without express authorization from RC Aero Products or its Authorized Sales, Parts, and Service Center.
- RC Aero Products or its Authorized Sales, Parts, and Service Center will not accept returns sent freight forward or COD.

### This Warranty does not cover the following items:

- Propellers, spark plugs and mufflers (custom) from other accessory manufacturers. They carry their own warranties, and the user should consult their manuals for information
- Crash damage. This includes propeller strikes of any type.
- Damage caused by using improper additives or fuel.
- Damage to an engine that has been modified or altered from its original design.
- Damage caused by improper handling, operation or maintenance. This includes the ignition system were damage is caused by excessive input voltage, vibrations damage or use without a spark plug installed and connected to the engine.
- Damage caused when the engine is shipped to the Repair Facility. **Pack Carefully.**
- Shipping costs and expenses to and from the Repair Facility for warranty service.

**NOTE:** We cannot ship replacement parts until we inspect the suspect items and they are deemed defective by the Repair Facility

## **RC Aero Products Authorized Sales, Parts, and Service Center**

**51 Hillside Dr.,  
Beacon Falls, CT 06403**

**Attn: Bill Jensen  
Phone and Fax: 203-888-4819  
Email: [wbilljensen@cs.com](mailto:wbilljensen@cs.com)**

# Customer Procedures for Warranty Work

Ok... your engine is hurt, and you want your problem fixed. The engine is still under warranty. So what do you need to do, to get things done and your engine fixed.

1. Contact our Service Center. Please. By contacting us first we might be able to help you with your issue before sending the engine back to us. We might be able to resolve your problem or even ship you the replacement part, depending on your claim.
2. If it is determined that you need to ship your engine to our Service Center, you will need to pack your engine. Here are some items to think about:
  - a. Protruding items like MUFFLER(S), SPARK PLUG(S) AND PROP ADAPTER should be removed from the engine and carefully wrapped separately if they are being included.
  - b. Make a list of needs to be checked out or repaired. Be as specific as you can.
  - c. Include your name, address, telephone number and email address.
  - d. Please do not use Styrofoam peanuts or pellets to pack your engine.
  - e. Wrap the engine in bubble wrap – use the large bubbles ones. Go about 4 or 5 times around the engine and tape it down.
  - f. Use a box that fits the bubble wrapped engine.
  - g. Once the wrapped engine is in the box, put the other items in next. The other items should also be packaged with bubble wrap.
  - h. When all the items are in the box, use crushed paper to stuff into any gaps around the engine and box.
  - i. Put your note into the box, and seal the box.
3. Notice to international customers: Please be aware that brokerage charges may apply if you declare a customs value of \$200USD or more when using a commercial carrier's ground service. For instance, UPS Standard (ground) service from Canada charges BJ's \$28.50 USD for a declared value of \$495. Also, you will not be able to insure the package for more than the declared customs value! Inquire with the shipping carrier that you select for info on how to avoid customs and brokerage charges. If we are billed for these charges, we will expect reimbursement from you. The best choice is the postal service, as we have never been charged these fees with them. Be sure to note in the customs declaration "Model Engine Returned for Repair". Check with our Service Center if you have questions before shipping.

# Repairs Repairs Repairs

## What to do

If your engine ever needs non warranty repair, RC Aero Products recommends that you use our Authorized Sales, Parts, and Service Center:

**51 Hillside Dr.,  
Beacon Falls, CT 06403**

**Attn: Bill Jensen  
Phone and Fax: 203-888-4819  
Email: [wbilljensen@cs.com](mailto:wbilljensen@cs.com)  
Web: [www.bj-model-engines.com](http://www.bj-model-engines.com)**

Contact BJ's for all repairs, warranty and non-warranty.

note: The customer is responsible for:

- SHIPPING COSTS ON ALL REPAIRS, both ways. Return packing, shipping, and insurance \$18, twins \$24 domestic ground, approximately.
- Consequential damages of any type or amount.

General repair info:

**Estimates:** For common repairs, you may do your own estimate on-line at [www.bj-model-engines.com](http://www.bj-model-engines.com); or, email, phone, or fax for a prompt free estimate.

**Quotes:** Accurate, detailed, diagnosis and repair quote with disassembly as required; included with repair, \$30 minimum without repair plus return S&H. Twins may be higher.

**General:** Minimum charge for repairs and quotes: \$30. Typical repair labor charge \$25/hr. Payment required before return shipping. Allow about 10 workdays in our shop for most repairs. Please include muffler, prop nut and washer. No need to send the prop, but, specify prop size and type if you have a favorite,

**Return packing and shipping:** \$18 for singles, \$24 for twins.

**Payment options:** *Major credit cards, PayPal, check, money order.*

# Contact Us

**RC Aero Products is a customer focused Company. Our aim is to produce the best gas engine for giant scale aircraft. Our goal is to ensure our customers have total confidence and trust in our power plants.**

**You can contact us by email -**

**support@zrcgf.com**

**We will get back to you as fast as possible.**

**You can contact us by phone**

**1-(905) 688-3947 -**

**Hours of operation – Monday – Friday 8:30am – 5:00 pm**

***Additional engine news, information and drawings are available at our Web site.***

**www.zrcgf.com**

**RC Aero Products**

Tel: 905.688.3947

sales@zrcgf.com

www.zrcgf.com

***Giant scale engines that surpass expectations***