

# INSTRUCTION MANUAL



# KINGTECH K80E

MNM©2009

## **PURCHASE AGREEMENT, FULL ASSUMPTION OF LIABILITY AND INDEMNITY AGREEMENT**

Buyer purchases from Kingtech, or from one of Kingtech's authorized dealers, a **MINIATURE TURBOJET ENGINE** for model aircraft, cars or boats ("Model Engine") for the invoice price, accompanying this sale, and Buyer and Kingtech agree to all of the following terms and conditions:

- 1. Buyer's Representations.** Buyer represents that he/she is very experienced in model airplane operation, and that all of the information set forth in the Purchase Application is true and correct. Kingtech relies on such representations, and would not enter into this sale but for these representations.
- 2. Buyer's Acknowledgment of Risks and Dangers.** Buyer recognizes that operation of the Model Engine may be dangerous, and that under certain circumstances, its handling will be dangerous. As set forth in Paragraph 3 below, Buyer accepts full responsibility for all of these risks and waives all liability as against Kingtech.
  - (a) Buyer's Acknowledgment of Danger.** Buyer expressly acknowledges that use of the Model Engine is dangerous if improperly handled, and could inflict injury if attempts are made to handle it properly, if the user does not fully acquaint himself/herself with the Model Engine's operation procedures. The Model Engine may cause burns to the user, or the user's assistant, particularly in the start-up procedure, and Buyer agrees to use extreme caution. The Model Engine exhaust is extremely hot, and will burn someone or something placed directly behind the exhaust tube. Highly flammable liquid is used to operate the Model Engine, and it or its fumes will ignite easily and flare up rapidly. The Model Engine itself remains extremely hot, after it is shut off, and requires a cooling down period. Improper use of the Model Engine, or failure to follow Academy of Model Aeronautics ("AMA") guidelines and rules will result in injury to the user, the user's assistant, or bystanders. Operation of the Model Engine in any location other than an approved location, and under safe circumstances could lead to injury to bystanders. A risk exists from explosion, in the event of tampering, modifications leading to over-speed or extreme metal fatigue.
  - (b) Buyer's Obligation to Become Fully Acquainted With Operation Procedure.** Buyer acknowledges receipt of operating instructions for the Model Engine which depicts its handling and operation. Buyer agrees to thoroughly acquaint himself/herself with these materials, and to require his/her assistant to become equally familiar with them. Buyer expressly agrees not to allow any person to assist in the start-up procedure of the Model Engine, who has not become thoroughly familiar with these materials.

**(c) Agreement to Use Qualified Assistant in Start-Up Procedure.** Buyer acknowledges that the start-up procedure for the Model Engine cannot be safely done, without an assistant. Buyer expressly agrees to use an assistant, who is thoroughly familiar with the Model Engine and its operation as set forth above, on each occasion when the Model Engine is started up.

**(d) Warning to Bystanders.** Buyer acknowledges that injury or burns to bystanders could occur, during the start-up procedure or when operating the Model Engine. Buyer expressly agrees to take all steps necessary to assure that no bystander will be in a position to receive injuries during the start-up procedure, or while the Model Engine is running.

**3. Full Assumption of Liability; Waiver and Release of Kingtech.** Buyer assumes all risk of injury, harm and damage, of every nature whatsoever, to himself/herself and his/her property. Buyer fully and completely waives and releases any and all claims which he/she might have at any time arising out of the purchase, handling, or operation of the Model Engine. This assumption, waiver and release is complete, full, and comprehensive.

**(a) Release Even If Kingtech Is Negligent.** The waiver and release contained herein releases Kingtech from all conduct, no matter how it could be characterized or alleged. Kingtech shall not be liable for its own negligence, whether active, passive, primary, or secondary. Kingtech shall not be liable for its sole negligence. Kingtech shall not be liable for its willful misconduct. Kingtech shall not be liable based on any theory in strict liability in tort. Kingtech shall not be liable for any alleged breach of warranty, whether express or implied, of any nature whatsoever, whether a warranty of fitness for a particular use, merchantability, or otherwise. There is no warranty of merchantability; there is no warranty of fitness for a particular purpose; and there are no warranties which extend beyond the description on the face hereof or Kingtech's One Year Limited Warranty.

**(b) Waiver Effective for All Time.** The waiver and release contained herein is effective, without regard to the passage of time. It is effective indefinitely. It will not be changed by any modification to the Model Engine, to any later sale, or other changes in circumstances.

**(c) Release Extends to Kingtech and All Its Associates.** The waiver and release contained herein protects Kingtech, and all of its employees, officers, principals, owners, designers, and agents ("Associates").

**4. No Modifications to Model Engine.** Buyer agrees to make no modifications of any kind to the Model Engine. This Agreement pertains to the entire life of the Model Engine.

- 5. Sale By Buyer to Other Party.** Buyer agrees to fully inform any person to whom he/she sells or transfers the Model Engine, concerning the handling, use, and operation of the Model Engine, and agrees to give all operating instructions to such person, at or before the time of sale or transfer. The indemnity and hold harmless agreement contained in Paragraph 3 continues in effect, following such sale or transfer.
- 6. Severability.** In the event any clause, provision, or term of this Agreement is held to be ineffective, void or otherwise unenforceable for any reason, that clause, provision, or term shall be severed from this Agreement, and the Agreement shall otherwise remain binding and effective. If any portion of Paragraph 3 is found to be unenforceable, then the parties agree that the fullest and most complete waiver and release which is permitted by law, shall be effective.
- 7. This Document Is the Full Expression of Parties' Agreement.** This Agreement contains the full and complete agreement of the parties. There is no representation, term, or provision which is outside this Agreement. Any and all discussions, oral agreements, and representations are merged into this single written Agreement. This Agreement cannot be modified or amended in any way, except by written Amendment, signed by the parties.
- 8. Paragraph Headings Not Controlling.** The heading to any paragraph, or subparagraph of this Agreement, shall not be dispositive, but may be used to interpret the parties' intentions.
- 9. No Interpretation of Agreement Against Either Party.** Buyer understands and expressly acknowledges that he/she has the right to have an attorney read and review this Agreement, before execution. This Agreement shall not be interpreted against either party, but shall be interpreted as if it was drafted mutually by the parties.
- 10) If the Buyer is not prepared to fully accept the PURCHASE AGREEMENT, FULL ASSUMPTION OF LIABILITY AND INDEMNITY AGREEMENT, the Buyer is advised to return this Model Engine immediately in new and unused condition to the place of purchase.**

## Kingtech Lifetime\* Limited Warranty

Kingtech warrants that this MINIATURE TURBOJET ENGINE for model aircraft, cars or boats ("Model Engine") enclosed with this warranty statement is free from defects in materials and workmanship during normal usage, according to the following terms and conditions.

1) The limited warranty extends to the original purchaser ("Buyer") of the Model Engine and is not assignable or transferable to any subsequent purchaser / end-user.

2) Warranty coverage begins the day you buy the turbine to the day you sell or crash turbine (which ever comes first), all parts except for batteries, electric motors, glow plug, valves, ECU & HDT, pump and frictional materials will be repaired or replaced free of charge. All parts, including repaired and replaced parts are covered for the original warranty period. When the warranty on the turbine expires, the warranty on all replaced and repaired parts also expires. The ECU is warranted for 1 year of purchased.

3) Buyer must fully accept all conditions of the PURCHASE AGREEMENT, FULL ASSUMPTION OF LIABILITY AND INDEMNITY AGREEMENT

4) During the warranty period Kingtech will repair or replace, at Kingtech's option, any defective parts with new or factory rebuilt replacement items if such repair or replacement is needed because of Model Engine malfunction or failure during normal usage. No charge will be made to the Buyer for any such parts. Kingtech will also pay for the labor charges incurred by Kingtech in repairing or replacing the defective parts. The limited warranty does not cover defects in appearance. Kingtech shall not be liable for any other losses or damages.

5) Upon request from Kingtech, the Buyer must prove the date of the original purchase of the Model Engine by a dated bill of sale or dated itemized receipt.

6) The Buyer must bear the cost of shipping the turbine to and from Kingtech, Taiwan.

7) The Buyer shall have no coverage or benefits under this lifetime warranty if any of the following conditions are applicable

a) The Model Engine has been subject to abnormal use, abnormal conditions, improper storage, unauthorized modifications, unauthorized repair, misuse, neglect, abuse, accident, alteration, improper installation or other acts which are not the fault of Kingtech, including damage caused by shipping.

b) The Model Engine has been damaged from external causes such as crash damage, foreign object damage, weather, Act of God, improper electrical connections, or connections to other products not recommend for interconnection by Kingtech.

- c) The Model Engine is operated for commercial or institutional use.
- d) The Model Engine serial number has been removed, defaced or altered.
- 8) If a problem develops during the warranty period, the Buyer shall take the following step-by-step procedure:
- a) The Buyer shall ship the Model Engine prepaid and insured to Kingtech, Taiwan.
- b) The Buyer shall include a return address, daytime phone number and / or FAX number, complete description of the problem and proof of purchase.
- c) The Buyer will be billed for any parts or labor charges not covered by this warranty.
- d) If the Model Engine is returned to Kingtech during the warranty period, but the problem with the Model Engine is not covered under the terms and conditions of this warranty, the Buyer will be notified and given an estimate of the charges the Buyer must pay to have the Model Engine repaired, with all shipping charges billed to the Buyer. If the estimate is refused, the Model Engine will be returned freight collect. If the Model Engine is returned to Kingtech after the expiration of the warranty period, Kingtech's normal service policies shall apply and the Buyer will be responsible for all shipping charges.
- 9) The Model Engine consists of newly assembled equipment that may contain used components that have been reprocessed to allow machine compliance with Model Engine performance and reliability specifications.
- 10) Kingtech shall not be liable for delay in rendering service under the limited warranty, or loss of use during the period that the Model Engine is being repaired.
- 11) Kingtech neither assumes nor authorizes any other person or entity to assume for it any other obligation or liability beyond that is expressly provided for in this limited warranty.
- 12) This is the entire warranty between Kingtech and the Buyer, and supersedes all prior and contemporaneous agreements or understandings, oral or written, and all communications relating to the Model Engine, and no representation, promise or condition not contained herein shall modify these terms.
- 13) If the Buyer is not prepared to fully accept the liability associated with the use of this Model Engine, the Buyer is advised to return this Model Engine immediately in new and unused condition to the place of purchase.
- 14) This lifetime warranty allocates the risk of failure of the Model Engine between the Buyer and Kingtech. The allocation is recognized by the Buyer and is reflected in the purchase price of the Model Engine.

## TABLE OF CONTENTS

	PAGE
<u>INTRODUCTION</u> .....	8
<u>SAFETY PRECAUTIONS</u> .....	9
<u>THE CHECKLIST</u> .....	10
<u>BEFORE RUNNING THE TURBINE</u> .....	10
<u>AFTER STOPPING THE TURBINE</u> .....	10
<u>FUEL / FUEL CARE</u> .....	10
<u>FUEL SYSTEM</u> .....	10
<u>HOPPER TANK</u> .....	11
<u>PRIME THE PUMP AND SYSTEM</u> .....	11
<u>FUEL SYSTEM CONNECTION DIAGRAM</u> .....	12
<u>FUEL PUMP ADJUSTMENT</u> .....	12
<u>STARTING GAS DIAGRAM</u> .....	13
<u>GAS INSTALLATION / FILLING THE STARTING GAS TANK:</u> .....	14
<u>MOUNTING THE TURBINE</u> .....	15
<u>SUGGESTED TURBINE INSTALLATION</u> .....	15
<u>CONNECTIONS AT THE TURBINE</u> .....	15
<u>ELECTRICAL CONNECTION PICTURES / DIAGRAMS</u> .....	16
<u>POWER SUPPLY</u> .....	18
<u>GLOW PLUG</u> .....	18
<u>XICOY ECU VERSION 7 INTRODUCTION</u> .....	19
<u>SETTING UP THE ECU</u> .....	20
<u>“LEARN R/C”. TEACH THE ECU TO THE R/C SYSTEM</u> .....	21
<u>THROTTLE CURVES / TEST FUNCTIONS</u> .....	22
<u>TURBINE STARTING / RUNNING</u> .....	23
<u>TURBINE STOPPING / COOL DOWN</u> .....	24
<u>RUN MENU</u> .....	24
<u>FADEC STATUS MESSAGES</u> .....	26
<u>FADEC WARNINGS</u> .....	26
<u>DIAGNOSES</u> .....	27
<u>SPESIFICATIONS</u> .....	28
<u>PARTS LIST</u> .....	29
<u>CONTACT DETAILS</u> .....	30

## Introduction

Welcome to use the Kingtech company's turbo-jet engine. We will provide you with the perfect after-sales service and technical support.

Obviously, model turbine aviation - despite all the apparent fun involved - is serious business. All Kingtech turbine jet engines have been through an extensive period of R & D and testing. To begin, read this manual thoroughly. Develop an overall impression of the engine and its operating procedures, measuring equipment and accessories. Study the material step-by-step and ascertain how to install, operate and maintain your turbine engine. If you are unsure about anything, re-read it again.

**DO NOT OPERATE THE TURBINE BEFORE YOU HAVE READ THE MANUAL AND FULLY UNDERSTAND EVERY PROCEDURAL DETAIL**

Once you are accustomed to handling the *Kingtech turbine*, you will observe that it is a very reliable engine. Some experienced operators have expressed their belief that it handles better than many piston engines. However, always remember this is a **REAL JET ENGINE**, requiring knowledge, discipline and maintenance.

In order to learn more about the development of the model turbine engine and understand its function, we highly recommend reading *Gas Turbine Engines for Model Aircraft* by Kurt Schreckling and *Model Jet Engines* by Thomas Kamps. These books are available through:

Traplet Publications

Traplet House

Severn Drive

Upton upon Severn, Worcestershire ISBN 0 9510589 1 6

United Kingdom WR8 0JL ISBN 0 9510589 9 1

## **Safety Precautions**

**ALWAYS ENFORCE THE PROPER MINIMUM SAFE DISTANCES FROM THE TURBINE!**

**In front = 15 feet   On the side = 25 feet   Behind = 15 feet**

**In case of a mishap, fire extinguishers should be on hand at all times. We recommend the CO2 variety.**

**To the avoid hearing damage, always use hearing protection when you are near a running turbine engine!**

**When the turbine is running, never place your hands into the area of the intake. An extreme suction - which can grasp a hand, fingers or other objects in a flash - prevails in this area. Be aware of this source of danger, always!**

**Prevent foreign materials from entering the intake or exhaust when working with the turbine. Before operation, make sure there are no lose parts or debris near the turbine. Objects being sucked in can cause severe damage.**

**Always exercise caution around the hot parts of the turbine, to avoid burns. The outer case at the turbine stage and nozzle reaches 450-500° (Celsius), while the exhaust gas may exceed 720 °C.**

**Assure that the fuel is mixed with approximately 5% synthetic oil. Use only synthetic turbine oils available at local airport fuel suppliers.**

**Never run the turbine in a closed room, or an area near any kind of flammable matter. Do not fly turbine-powered aircraft near flammable materials, nor in forested tracts or areas experiencing drought or dryness. Obey all forest fire regulations and warnings by refraining from operating turbine in restricted fire zones. Never operate model turbine jet aircraft in or around residential or heavily populated areas.**

**Installation of unauthorized parts from another manufacturing source may also result in engine failure**

### **Warning:**

**A flying model with a turbine can reach higher flight speeds than ducted fan-powered models, because the turbine's thrust degrades less with higher flight speeds. With attainable flight speeds of over 250 MPH, you can quickly run out if flying room. There is also a danger of developing control surface flutter or mechanical overload, causing the model to fail in flight. When piloting a turbine powered aircraft, one must properly control the throttle. Full power should be used for takeoff or vertical maneuvers and a reduced setting for level or descending flight**

## The Checklist

### Before Running the Turbine

- Charge ECU Battery
- Prepare fire extinguisher
- Check fuel lines and filter. Make sure they are clean with no restrictions
- Check that the fuel tank vent is unobstructed
- Fill fuel tank(s). Make sure the main and header tanks are full
- Prime pump. Take good care not flooding turbine.
- Be certain the starting gas release valve is closed, before filling the starting gas tank
- Turn on receiver switch
- Place the model with nose into the wind
- Activate brakes and start turbine

### After Stopping the Turbine

- Turn model into the wind. Activate brakes and stop turbine
- After the cooling process (approximately two minutes), turn off receiver switch
- After each flying session, open starting gas release valve, to empty the tank, before storing the model. This should be executed in a safe area

## Fuel / Fuel Care

The *Kingtech* engine use 1-K kerosene or Jet-A1 for fuel. Fuel must be mixed with 5% synthetic turbine oil.

Example formula: 1 quart of oil in 5 gallons of fuel. We recommends Aeroshell 500 turbine oil.

## Fuel System

The input and output fuel tubing must be connected to the electronic shut-off valve as per the drawing.

When installing the fuel lines on components with nipples, slightly warm the tubing before connecting. This will soften the tube, making it easier to install. When installing tubing on a metal tube, secure the tubing by placing a tie-wrap around the connection. To remove tubing from nipples, you must cut the tubing off. Be careful not to damage the nipple when cutting off tubing. To insert tubing into Festo quick release fittings, use firm pressure until you feel the tube snap in. To release, press in on the front ring, while pulling the tubing out.

**ALWAYS** use a gasoline-compatible stopper. Silicon stoppers swell and leak. Check your fuel filters every ten (10) flights. You may be surprised how rapidly they can clog up! The filter is installed with the O-ring located toward the fuel pump. Use caution not to pinch o-ring when assembling filters. We recommend mounting the fuel filter vertically. This will limit the possibility of air being trapped inside and then coming out at an inopportune time. It is also better not to affix it but to leave it free to slightly move.

When running the engine at full power, check the fuel line from the pump to the engine. If there is a large quantity of air bubbles flowing with the fuel, there is probably a restriction in the fuel system or an air leak in a fitting.

Be careful not to over-pressurize the kerosene tanks and the kerosene shut off valve during refueling operations. You might pump a bit of raw fuel past the valve and into the turbine, and subsequently have a wet (hot!) start. We are now requiring a manual shutoff valve downstream of the automatic kerosene shutoff valve, as an additional precaution.

## **Hopper Tank**

A hopper tank is recommended, between the main fuel tank and the engine. Kingtech highly recommends the BVM UAT for the hopper tank! Always use the filter between the fuel pump and the solenoid valve as shown in the diagram. This is true even when using the BVM UAT! The pump will emit small particles that can block the solenoid valve from completely closing!

## **Prime the pump and system.**

To prime the fuel pump and fuel lines (or for fuel pump test purposes), it is necessary to open the fuel shutoff valve and run the fuel pump manually. For this purpose, use the Test Menu selection, Prime pump. This test opens the fuel valve and acts as a speed control for running the pump. (page 22)

### **Extremely Important:**

Pump Test allows the fuel pump to operate without the turbine running. However, if the fuel feed line is not removed from the turbine during this procedure; it will become flooded with fuel. When this occurs, the next turbine start can become highly combustible!

**Before activating the pump test mode, ALWAYS remove the fuel feed line connected to the turbine.**

## Fuel System Connection Diagram

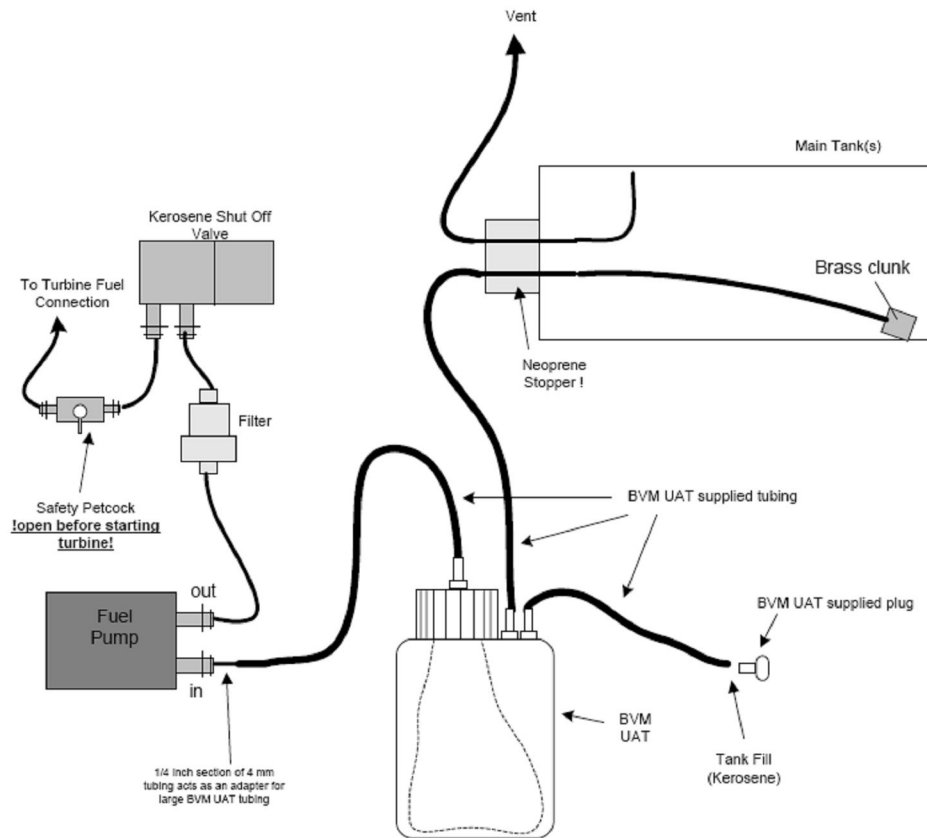

Note: All tubing 4mm(except as noted)

## Fuel pump adjustment

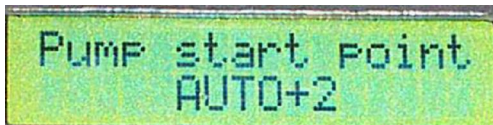

**Pump Start point:** Sets the power of the pump when it is started at beginning of the fuel ramp. The FADEC have the ability of to automatically adjust the pump power to start it at the lowest possible speed, independently of the battery voltage and pump roughness. Also the user have the possibility to adjust the minimum pump power manually.

**AUTO mode:** The values of "Pump start point" from 0 to 8 are in AUTO mode.

This means that the FADEC will adjust itself the pump power to start it slowly. The usual value for a unknown engine is AUTO+2, but after the first start you can increase or decrease the fuel flow if needed.

## Starting Gas Diagram

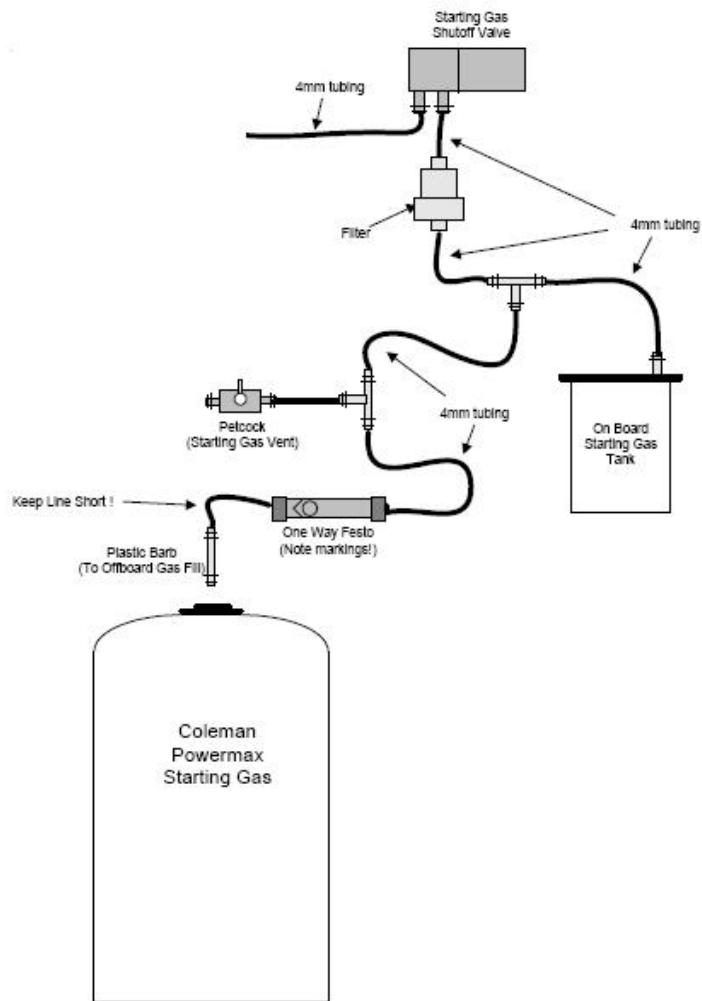

## Gas installation

Some modelers prefer to install gas in jet. When setup correctly no connections to jet is needed when startup. If you will not use onboard gas, then you may skip these steps. Keep the tubing length short from the one/way valve to the black nylon starting gas probe. This will minimize the amount of excess gas released when the probe is removed from the POWERMAX can.

The starting gas tank can be mounted vertically or slightly horizontally. Whether the tank is mounted upright or slightly on its side, the nipple must always be towards the top. This will limit the amount of liquid propane entering the turbine during startup.

After every flying session, open the release valve to empty the tank, before storing the model. Perform this procedure in a safe area.

The propane filter is installed just before the starting gas valve.

If you are using the engine in a bypass, and it produces a bang when the starting gas ignites, or if it is too rich and not igniting immediately, you must limit the amount of starting gas flowing to the turbine. This is accomplished by changing the Gas % to a lower value. Start by lowering it in 10% increments until it smoothly ignites. This should be adjusted with a full tank of gas each time. Watch the exhaust gas temperature each time you make an adjustment. The turbine will over heat if the amount of starting gas is too low. When a good adjustment is achieved, it should work unless there is a broad change in outside temperature.

## Filling starting gas

Only use a propane/butane mix for starting gas. We recommends Coleman POWERMAX fuel (or a mix of propane butane 60/40%). Do not use 100% propane from torch refill bottles. The pressure is too high and will cause the tubing to rupture.

To fill the tank, insert the starting gas fill probe into the valve on the POWERMAX can. Make sure the can is vertical since it has a clunk at the bottom. Verify that the fluid is flowing into the tubing. Continue filling, until the fluid slows. Just before the liquid stops flowing, remove the probe from the POWERMAX can. Although several starts are attainable with a full tank, we recommends refilling before every flight, establishing a routine that is not overlooked.

Do not over fill the on-board starting gas tank. When you notice the liquid flow into the tank start to slow down, stop filling. You will prevent any tendency to "pop" on start up, while still having enough gas for 2 to 3 auto starts.

## Mounting the Turbine

A two-piece, aluminum mounting bracket is included with the turbine. Place the bracket around the turbine, with the glow plug situated within the slot of the smaller bracket piece. This will help stabilize the engine along the thrust axis. The glow plug must be in the vertical position, when mounted in your model (+/- 75° of engine rotation, from the glow plug at top dead center, is the allowable deviation). Secure the engine, using four metric mounting screws and lock washers that are provided with brackets.

## Suggested turbine installation

When the turbine is mounted in models with the air intake at the bottom, for example F-16, care should be taken to prevent foreign object damage of the compressor stage. This can be accomplished by using a strainer screen at the inlet. The screen mesh should be about 0.06 inches in width.

## Connections at the turbine

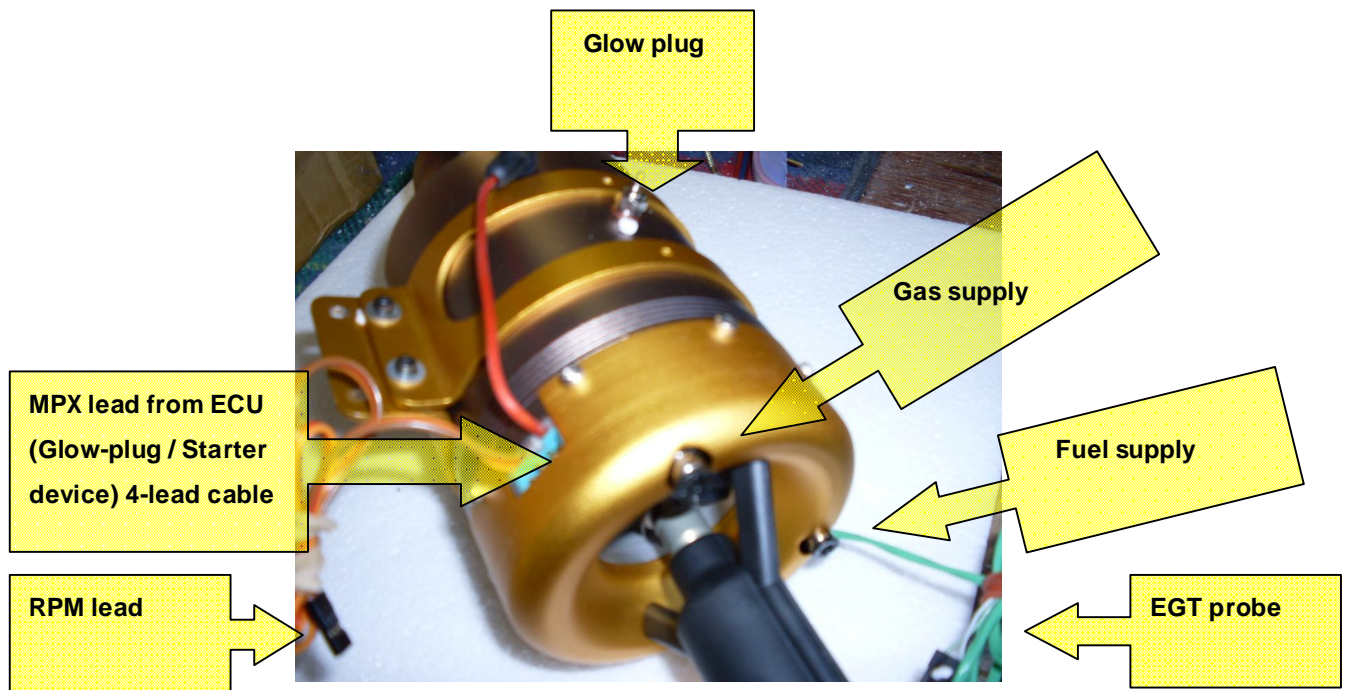



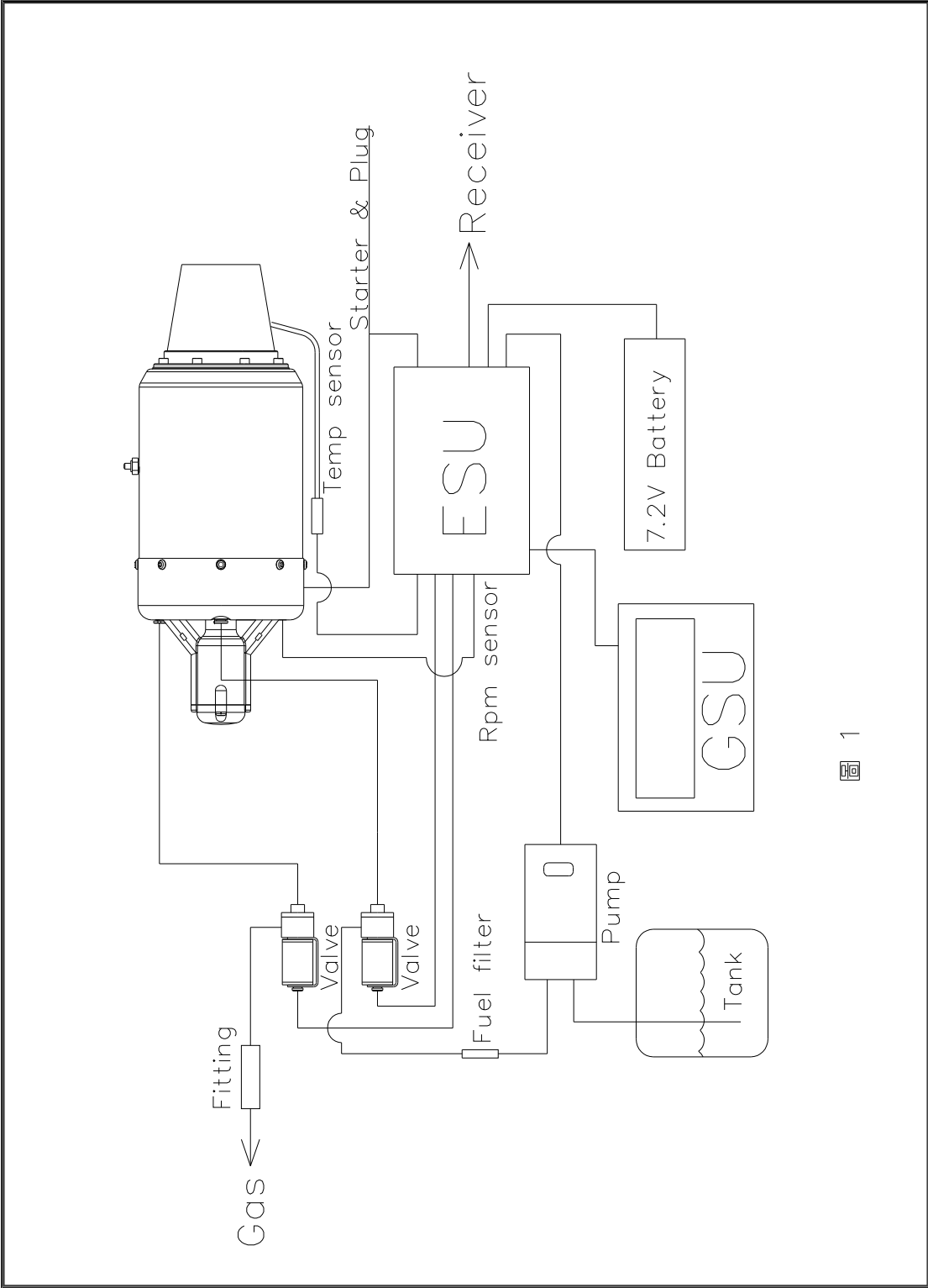

## Power Supply (not included)

Power for all electrical components of the turbine (starter / glow plug / ECU / fuel pump / fuel and gas valves) are supplied by the six-cell, 1500 mah ECU battery. The amount of battery capacity used per flight is approximately 300-400 mah. This includes starting and cool down. The ECU NiCad battery must be recharged after two (2) flights! We recommends recharging after every flight, making it a routine that is not overlooked. The battery should be cycled periodically, to prevent NiCad memory problems that lower the battery's capacity.

### Charging the Battery

Do not charge the battery, with a quick charger using negative discharge pulses, when connected to the ECU. This will destroy the electronics of the ECU. The only recommended method is to disconnect the battery from the ECU and charge it directly.

### Glow Plug

A modified, (non-idle bar) glow plug OS no8 is appropriate. The glow plug is installed on the turbine with the washer. Do not over-tighten or you may damage the threaded bushing. Light torque is fine; there is no vibration to loosen it. The glow plug is modified, so that two turns of the element extend beyond the bottom of the plug. With a pin, pull out two turns of the element. Make sure the plug glows brightly red. The limits menu features an adjustment for glow plug voltage. If higher voltage plugs are used a value of 2.6-2.7 V will be required. This adjustment is described later.



Note: 2 coils  
pulled out 90°

## **Description of the FADEC.**

The FADEC (Full Authority Digital Engine Control) is a total system for the control of a model gas turbine engine. Its main function is to control and regulate the fuel pump, providing to the turbine engine the necessary amount of fuel for safe and controlled operation, and to operate the ancillary devices for starting. The FADEC measures the exhaust gas temperature, the relative position of the throttle stick and the rotor speed. It monitors all of the controls necessary to guarantee that the engine stays between the user defined parameters of operation, also providing failsafe shutdown of the engine when it has detected any important anomaly. In order to make this assessment, the FADEC has a rpm sensor, a thermocouple input, a throttle servo input, power connections for the fuel pump, starter, glow plug, fuel and gas valves and the battery and a digital (RS232) serial port to program and read the data in real-time to a PC. The measurements made by the FADEC are:

- Temperature of the exhaust gas
- Battery voltage
- Battery current
- Width of the throttle pulses from the radio transmitter
- Engine rotor RPM
- Engine run time.
- External analog signal (airspeed sensor)

### **Features:**

- RPM input: Magnetic sensor up to 250.000 R.P.M.
- Temperature range up to 1000°C using a "K" type thermocouple
- PWM control of 8192 levels for pump, glow plug and starter motor.
- Adjustable power for the starter motor
- Build-in electronic brake for the starter motor to help the clutch to disengage.
- Blown glow-plug detector
- Adjustable glow-plug power
- Glow-plug temperature independent of the battery voltage
- Elapsed engine run timers
- RS232 interface to interface to a PC.
- Black box function. Record the engine measures each 0.5sec up to 52 minutes.
- Radio link error counter
- Battery usage counter in mA/h
- Test functions for all connected devices.

## Setting up the ECU

All the programming and measures are done through the data terminal. Once the FADEC is programmed, it is not necessary its use and it is not recommendable to leave it inside the airplane to minimize the risk of interferences. The data terminal has a 16 character LCD screen and 4 buttons. The first two buttons on the left side allow moving through the menus, and the two buttons on the right side allow changing the data. Main screen, as shown in the picture, give to the user that main readings from the engine. These are the FADEC status, the EGT (temperature), RPM and pump power.

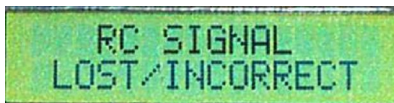

In the case of an error, this screen changes to the error screen every 2 seconds.

Pressing the second button from the left (Menu Up) the second informative screen is shown. In the first line you have the measure of the pulse width received from your RC system, and the relative stick position. Second line show the voltage of the battery and the software version. If the current drawn from the battery is higher than 0,5A, then the FADEC display the battery voltage and the battery current in Amperes.

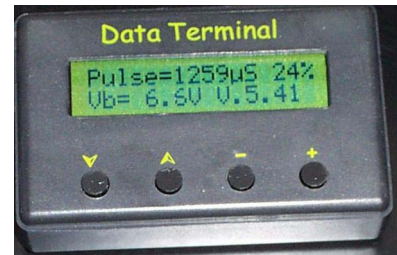

Next menu let you to choose in four submenus, selected by pressing the button under of each option.

**Start:** Jump to the parameters used on startup

**Info:** Information and test menus

**Radio:** Adjust the radio throws

**Run:** Set the parameters used during engine run.



It is recommended that the first adjust be the one of the radio:

## Learn R/C. Teach the ECU to the R/C System

Turn on the transmitter and receiver. Using the “menu up” and (-) buttons move to the “Radio” menu. First screen will be this one:

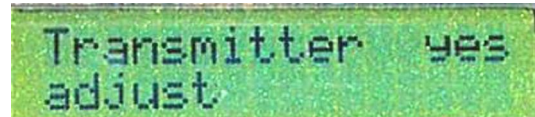

Transmitter yes  
adjust

If you are sure that you want to modify the radio settings then press the right hand button (+) and the screen will change to:



Stick UP Trim UP  
(Full Power)

On your transmitter, raise the throttle

stick and trim to full. Ensure stick is firmly against the stop. Now holding the stick against the stop, press the right button (+) to set the value into the FADEC.

**IMPORTANT NOTE:** Pressing any other button the setting WILL NOT be stored.

The screen will now change to:

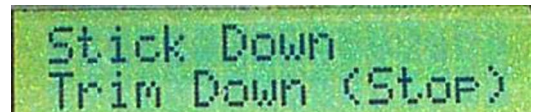

Stick Down  
Trim Down (Stop)

Move the trim (or switch the “engine cut” switch to on) and throttle stick back to zero and again press the right hand button (+).

The display will now change to:

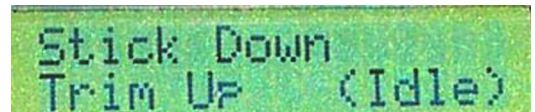

Stick Down  
Trim UP (Idle)

Leaving the throttle stick in the minimum position, raise the throttle trim to the full up position or switch “Engine Cut” switch to off, and again press the “+” button. The FADEC will store the current position as IDLE.

If you have done all steps correctly the green LED located directly above the data terminal socket will light up in the ECU when the “Idle” command, (trim and throttle stick set to idle positions on the transmitter). Lower your throttle trim and the green LED will go out indicating correct reading of the transmitter engine shut off signal by the FADEC. On rare occasions, usually when using a Futaba transmitter, it has been found that the throttle channel sense of movement may require reversing (Servo reverse) and repeat the transmitter alignment.

Correct reading of throttle % by the FADEC can be verified in the second screen, percentage of the throttle position is shown on, 0% in the position of engine stop (trim and stick down), 100% with stick/trim full up and between 10% and 30% at idle.

This now completes your radio setup and should only need doing again if the radio settings in the TX are changed.

## Throttle curves

By default the FADEC control the RPM in linear way, i.e. at half stick position the engine turn at half of the rotor RPM range. Jet engines develop the thrust in exponential mode, thus half RPM means approximately ¼ of thrust. On small engines with a high idle to full power rpm ratio, or in a high drag/low power planes, often only the last 1/3 of the throttle stick produce significant thrust, with the low half stick travel being not used. Although that with current digital TX the pilot can modify the throttle curve to suit his needs, from version 5.48 three throttle curves have been added to simplify the setup for most of the installations:

**FULL EXPO:** Mean linear RPM, it is the default setting and the mode used for all previous software versions. Thrust develops exponentially, and it is the ecommended curve for big engines or/and high thrust/weight ratio planes, as it ease the control in low power used during taxi.

**LINEAR:** Mean that the thrust develop linearly with the throttle setting. Could cause difficult taxi, as it would be difficult to fine adjust the power at low settings.

**HALF EXPO:** A intermediate setting between the other two modes.

MODE	Stick position					% of total thrust
	0% (Idle)	25%	50%	75%	100%	
FULL EXPO	Idle thrust	6%	25%	56%	100%	
HALF EXPO	Idle thrust	16%	38%	66%	100%	
LINEAR	Idle thrust	25%	50%	75%	100%	

## Test functions

The FADEC provides several menus to test the starter motor, glow plug, pump and solenoid valves. These test screens are only available when the FADEC is on "Trim Low" status, that is to say, recently powered up and receiving a STOP signal from the TX. Pressing the (-) button (under the "ON" reading on the screen) will energize the selected device and pressing (+) will shut down. Special care should be taken when testing the pump, as it is possible that fuel can be pumped into the engine, flooding it, and causing a hot start on next startup.

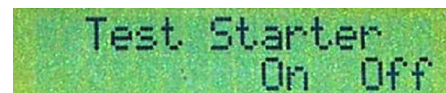

```

Test Starter
  On  Off
    
```



```

Test Glow-Plug
  On  Off
-----
Test/Prime Pump
Caution! On  Off
    
```

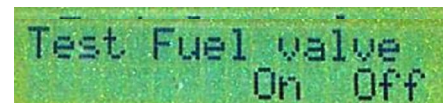

```

Test Fuel valve
  On  Off
    
```

## **Turbine starting and running**

**Always set-up and confirm the operation of your Auto-start installation on the test-stand, before installing into your model.**

**The present version of auto start uses only one channel for the entire engine functions: To trigger the auto start cycle, the process is as follows:**

- **The user raises the trim. "Ready" will appear on the HDT (Hand data terminal) screen. The trim and stick should be where the engine is supposedly to be to idle once running. If the trim is on "stop" position, "Trim low" will be read on the HDT. If higher than idle, "StickLo!" will be read.**
- **When "Ready" is displayed, the user should cycle the stick to full power and back to idle.**
- **When the stick is at idle again, the start sequence begins.**
- **The glow-plug is powered and checked. Once hot, the starter is engaged at reduced power (soft start) and the gas valve is energized. If the glow test fail, a "Glow Bad" message is displayed, and if the starter fails to arrive a minimum RPM in 2 seconds, a "start bad" message is issued, and the auto start function aborted.**
- **When the rotor arrives at more than the "ignition max rpm" programmed parameter (default 4000), the starter is disconnected and the brake applied.**
- **When the rotor RPM fall below than the "ignition min. Rpm" parameter (default 2000), the starter is switched on again to raise the rotor speed to the "ignition max rpm" and the cycle is repeated until the gas ignites or the system times out after 30s.**
- **When the thermocouple register a increase of 50°C in temperature meaning that the ignition have occurred, the starter is switched on immediately at reduced power, increasing his power accordingly to the real rotor rpm. At the same time the pump is switched on at "pump start point" power, and the fuel valve is opened.**
- **The engine begin to accelerate as soon as the fuel begin to burn, and the power of the pump is being increased trough the time at the "fuel ramp" slope. Once the rotor RPM arrive to the RPM set in "rpm switch off gas" parameter (usually set at 3/4 of the "starter off RPM") the gas valve is closed, and when the RPM arrive at the predefined "starter off RPM" value, the starter is switched off and the brake applied to it. The engine continues accelerating alone until the idle RPM are reached. Now the user can accelerate the turbine.**

## Turbine stopping and cooling

- The user can finish the sequence in any moment, simply setting the trim to "off" position. If the engine was on "running" phase (above idle rpm), a cooling sequence will be triggered, cycling the starter motor until the EGT is below the minimum programmed temperature. This cooling sequence will be aborted if the trim is raised again.
- If the engine is hot (EGT higher than the minimum temperature) at the moment that the user triggers the auto start cycle, then the FADEC will begin a cooling cycle until the temperature is below the minimum programmed temperature. At this moment it will continue with the normal auto start cycle if the trim is left in up position.

## RUN menus

On these submenus the parameters used for the engine during normal run can be modified. **Note: Some of these menus parameters can not be changed by user. It was factory set for best operation and to protect turbine. Please do not change these values set by factory. This may void your warranty!**

**Full power speed:** On this screen you can set the RPM that the engine will run at 100% throttle. If the engine manufacturer have set a upper limit, you will be able to reduce the maximum speed, but not to increase it beyond the limit. RPM 145 000

**Idle speed:** Set the RPM that the engine will run when the FADEC receive IDLE command. While the engine running the fadec will adjust the rotor speed accordingly the throttle position in a closed loop system. RPM 45 000

**STOP speed:** Set the minimum RPM that the engine is allowed to run. The FADEC will shutdown the engine if the rotor speed is below this setting. RPM 30 000

**Start/Min temperature:** Set the minimum temperature that the engine is allowed to run, and in manual start operation, sets the temperature from wich the pump begin to run. 100 DEG C

**Maximum temperature:** Set the maximum temperature that the engine is allowed to run. The FADEC will reduce the acceleration rate if the EGT approaches to maximum and will reduce the pump power if necessary to keep the temperature below the maximum, but it don't will cut the engine if the temperature is too high, it will try always to keep the engine running by reducing the fuel flow . 850 DEG C

**Acceleration delay:** Set the acceleration time on the engine. Higher values, longer acceleration times. The real acceleration time is calculated using a complex algorithm that take in to account this value, temperature, current RPM, commanded RPM, and the tendency of EGT and RPM.

**Deceleration delay:** Similar to the acceleration, but used during throttle down. Higher values mean slower deceleration.

**Stability delay:** When the engine is running at constant throttle setting, the FADEC is adjusting continuously the pump power so that the rotor RPM mach exactly with the throttle signal. The speed of witch the fadec adjust the pump power is set by this parameter. A value of 100 usually is the best for all engines. A too low value can cause instability on the RPM.

**Pump Limit:** The Fadec can give to the pump the full battery voltage, but in most cases the voltage needed for the pump is only a fraction of the full battery voltage. Limiting the pump give a much smoother control of the engine and prevents that the pump could receive excessive voltage in the case of a problem in the fuel circuit, a clogged filter for example. This excessive power will cause a high pressure on the circuit that can cause leaks or blown tubes. Modifying this parameter is similar to reducing the battery voltage, so the accel and decal times will be modified. The recommended adjust of this setting is to set it to 1020 (no limit) , run the engine, check and annotate the Pw of the pump displayed on the first screen when the engine is running at full power and then use this value as pump limit, increasing it in a 10%-20% to give a bit of margin for weak batteries and pump wear. Once the new value set, adjust the accel and decel delays for best engine handling.

## List of FADEC STATUS message codes

Here is a list of possible messages shown on the data terminal screen and their meaning.

**TrimLow:** Indicates that the signal received from the transmitter corresponds to the lowered trim, that is to say, engine OFF.

**Ready:** Indicates that the engine is ready for starting, and that the transmitter signal corresponds to IDLE, (green LED lit)

**StickLo!:** This indicates that the throttle stick is in a position above IDLE, the engine will not start with the stick in this position.

**Glow Test:** Verification of glow plug

**StartOn:** Test of the starter

**Ignition:** Gas ignition phase.

**Preheat:** Phase of heating of the combustion chamber after detecting the gas ignition.

**FuelRamp:** Phase of acceleration until speed of IDLE.

**Running:** Engine working correctly, pilot have full control of engine power.

**Stop:** Engine off.

**Cooling:** Starter operating to cool the engine.

**GlowBad:** Defective or disconnected glow plug.

**StartBad:** Defective starter, insufficient RPM reached during start.

**Low RPM:** Engine speed below the minimum.

**HighTemp:** Excessive temperature

**FlameOut:** Exhaust GAS Temperature below the minimum.

## List of FADEC Warning message codes:

**RC SIGNAL LOST/INCORRECT:** The signal received from the RX is wrong (outside calibration margin) or absent.

**PUMP LIMIT REACHED:** The fadec have increased the pump power up to the value set on the "Pump Limit" parameter, but the engine haven't arrived to full power. Causes could be flat battery, fuel restriction or anything that can cause a reduction in the fuel flow.

**xxxx OVERLOAD:** A excessive current is detected flowing to the specified output.

## Diagnoses:

During engine operation the FADEC measures and stores all the engine operating parameters recorded during the last the 51 minutes of operation. These measures can be downloaded later to a PC to study the behavior of the engine in flight and to diagnose any possible problems. Also, after each cycle of operation, the FADEC stores the last cause of shut down and the values of RPM, temperature and pump power at the moment of shutdown. In order to access these measures, it is necessary to reinitialize the FADEC (shut down and powerup).

Set the trim down (TrimLow) and push the left button on the display. The FADEC will show the cause of shutdown and the measured values at the moment of shut down.

These are as follows:

## Diagnosis messages:

**UserOff:** The engine has been shut down because it has received the shut down command from the transmitter.

**FailSafe:** The engine has been shut down because of loss of the control signal from the transmitter. Once the Ecu detects a loss or invalid RC signal for over 0,5s, it sets engine power to idle, and if after another 1,5seconds a valid signal is still not received the engine is shut down.

**LowRPM:** The engine has been shut down because the RPM has dropped below a minimum. Cause could be lack of fuel, air bubbles, problem with the batteries, or defective RPM sensor.

**FlameOut:** The engine has been shutdown because the temperature has dropped below the minimum of (100°C). (Usually a thermocouple failure).

**RCPwFail:** Lack of power from the radio receiver.

## Engine specifications

<b>Size:</b>	<b>Diameter 95.4 mm(In the engine's immovable box)</b>
<b>Length:</b>	<b>258 mm(including starter)</b>
<b>Weight:</b>	<b>1260 g(including starter)</b>
<b>maximum speed:</b>	<b>145000rpm</b>
<b>thrust:</b>	<b>8.0kg(18 lbs)</b>
<b>Idle:</b>	<b>45000rpm</b>
<b>Exhaust temperature:</b>	<b>650 deg C max</b>
<b>Fuel consumption:</b>	<b>250ml/min.(average)</b>
<b>Maintenance cycle:</b>	<b>25 hr USD300</b>

### Maintenance cycle included:

- Turbine dismantle
- Balance correction
- Turbine assemble
- Test adjust
- Replace of bearings and other friction parts determined by technical staff

## Parts list

Engine	-1pcs
Plug	-1pcs
Engine control system(ECU)	-1pcs
Engine control screen(HDT)	-1pcs
Connection line	-1pcs
JR TYPE extension of the line	-1pcs
Pump	-1pcs
Electromagnetic valve	-2pcs
Engine mount	-1pcs
Oil Filter	-1pcs
4mm pipeline	-1pcs
4-4 Quick connector	-1pcs
Manual	-1pcs



# **Kingtech Turbine Co.,Ltd.**

**[Http://www.kingtech-jet.com](http://www.kingtech-jet.com)**

**Office: No.171, Jiouda Rd., Dashu  
Township, Kaohsiung County  
840, Taiwan (R.O.C.)**

**E mail:kingtech5512@gmail.com**

**Tel:+8867-6523533**

**Fax:+8867-6524262**

**Service:+886-937337983**